



SERVICE CATALOGUE 2009

PRODUCTS AND SERVICES



CONTENT

STAND PACKAGE	4
ALUMINIUM BUILDING SYSTEM	6
WOOD BUILDING SYSTEM	9
PAINTING & FABRICS	10
CARPETS & FLOORING	11
ACCESSORIES	14
CHAIRS & TABLES	16
COUNTERS & PODIA	19
WATER, COMPRESSED AIR & KITCHENETTE	22
ELECTRICITY & LIGHTING	23
AV-TECHNOLOGY	24
AT YOUR SERVICE	26
GOODS	26
HANGING WIRES	26
HOSTS AND HOSTESSES	27
SECURITY PERSONNEL/FIRE OFFICER	27
PHOTOGRAPHER	27
CATERING	27
TRAVEL & ACCOMMODATION	27
STAND CLEANING	27
PARKING	27
ON SITE SERVICES	27
RESTAURANTS	27
GRAPHIC DESIGN	28
HOTEL	29
ADVERTISING SPACE	30
VISITORS REGISTRATION	31
INSURANCE	31
TECHNICAL INFORMATION	32
TERMS FOR INSURANCE	35



STOCKHOLM INTERNATIONAL FAIRS – THE NO.1 MARKET PLACE IN THE BALTIC SEA REGION

Stockholm International Fairs is one of the world's leading and most flexible organisers of meetings. We offer the perfect meeting place for everything from international summits to broad public fairs. Together with exhibitors and organisers we create well organised meetings which offer the visitor inspiration, knowledge and business opportunities. As the leading organiser in the Baltic Sea Region, we organise some 60 industry-leading exhibitions as well as around 100 national and international congresses, conferences and events annually. Each year we welcome 10,000 exhibitors, 1.5 million visitors and more than 8,000 journalists from all over the world.

EXHIBITOR SERVICE

In the Service Catalogue you will find all the services and products you need for your participation. Do not hesitate to contact Exhibitor Service if you have any questions.

ORDER EARLY AND SAVE MONEY

Please note that we charge 25 % extra for the following services if you order them during the official building up period: electricity, wire, heating, water, sanitation, Internet and telephony. So place your order early and save money!

THE DRAWING SYMBOL



Certain products are marked with a drawing symbol. To be able to install your products where you want them in your stand, please mark them on a drawing. You can see from the Order Form in the Service Catalogue how the products should be marked on your drawing.

ORDER YOUR STAND EQUIPMENT ON OUR WEBSITE

At www.stockholmsmassan.se you can find almost everything you need to know as an exhibitor at Stockholm International Fairs. Please take some time to look through the information under "Exhibitor info". Amongst other options, you can order products and services for your stand. When you have sent the Order Confirmation for your stand, you will also receive the login information you need to access the order function. All prices in the catalogue are rental prices exclusive of VAT for the entire exhibition period, unless otherwise stated. Stockholm International Fairs will not be liable for typographical errors and reserves the right to make price adjustments.

CHANGES/CANCELLATION

The full rate will be charged for any bookings changed/ cancelled less than 5 working days before the opening day of the fair. Not applicable to furniture.

CONTACT EXHIBITOR SERVICE

Telephone +46 8 749 44 44
Fax +46 8 99 70 05
E-mail us@stofair.se

STAND PACKAGE



ALFA, SEK 795/sqm (excl. stand space) Art.no 201100

ADVERTISING MATERIAL NOT INCLUDED

MATERIAL WOOD

Wooden walls painted white (for other colour options according to price list see page 10). Lockable area. (A padlock can be bought at Service Center.)

CARPETS FOR HIRE

Colour options, see page 11.

FURNITURE

1 coat stand,
1 white table (ø 900 mm) with adjustable height (500-700 mm),
4 black folding chairs (seat height 450 mm).

FASCIA BOARD

Aluminium fascia modules.
Lightweight boards in a variety of colours, see page 6.
Includes fascia board text in Helvetica, in black or white text. To add your logo to the fascia board, please see page 28.

LIGHTING

1 spotlight /4 sqm stand area.

ELECTRICAL CONNECTION

10 A connection, 1-phase 230V. Max 2000W.

CLEANING

Cleaning service during fair.

PLEASE COMPLETE THE ORDER FORM WITH YOUR SELECTED ITEMS.

MATERIAL ALUMINIUM

White fabric walls mounted in aluminium frame.
Lockable area.

CARPETS FOR HIRE

Colour options, see page 11.

FURNITURE

1 wall-mounted clothes hanger,
1 white table (ø 700 mm) with adjustable height (500-700 mm),
4 black director's chairs (height 460 mm).

FASCIA BOARD

Aluminium fascia modules.
Lightweight boards in a variety of colours, see page 6.
Includes fascia board text in Helvetica, in black or white text. To add your logo to the fascia board, please see page 28.

LIGHTING

1 spotlight /4 sqm stand area.

ELECTRICAL CONNECTION

10 A connection, 1-phase 230V. Max 2000W.

CLEANING

Cleaning service during fair.

PLEASE COMPLETE THE ORDER FORM WITH YOUR SELECTED ITEMS.



BRAVO, SEK 995/sqm (excl. stand space) Art.no 980000

ADVERTISING MATERIAL NOT INCLUDED

Book a stand package tailored to your stand space. These stand packages are available from 18 m². All stand packages include assembly of walls, choice of hired carpet, one electricity socket, spotlights, cleaning throughout the fair and your choice of furniture.

CONTACT EXHIBITOR SERVICE FOR MORE INFORMATION.



DESIGN Wood
Price example 24 m² SEK 29,800



DISPLAY Wood
Price example 30 m² SEK 30,750



MEETING Aluminium
Price example 24 m² SEK 28,300



INFO Aluminium
Price example 30 m² SEK 30,750

ALUMINIUM BUILDING SYSTEM

White is the standard colour for the wall panels that are supported by aluminium profiles. See below for additional colour options for walls and fascia panels. There may be colour discrepancies on fascia and wall panels.

SOME COLOURS CANNOT BE REPRODUCED EXACTLY FOR TECHNICAL REASONS. CONTACT EXHIBITOR SERVICE FOR COLOUR SAMPLES.

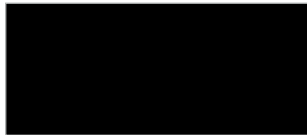

BLACK
Walls and fascia boards.



GREY
Walls and fascia boards.

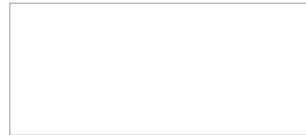

WHITE
Fascia boards (standard for walls).



BLUE
Walls and fascia boards.



RED
Walls and fascia boards.



YELLOW
Walls and fascia boards.



GREEN
Walls and fascia boards.



ENVIRONMENT WALL
Walls



FASCIA See colour samples for options. Height: 370 mm.
Art.no 982300 **SEK 295/running metre**

	RAMP	1. Mod. dim. (c/c)	2. Frame dim.	3. Exp. dim.
Height (mm):		370	285	270
Width (mm):	(0.5 m)	490 *	452	440
	(1 m)	980 *	942	930
	(1.5 m)	1,470 *	1,432	1,420
	(2 m)	1,960 *	1,922	1,910
	(2.5 m)	2,450 *	2,432	2,400
	(3 m)	2,940 *	2,902	2,890
	(3.5 m)	3,430 *	3,392	3,380
	(4 m)	3,920	3,882	3,870
	* Also available as 45° diagonal version	(4.5 m) 4,410	4,372	4,360
		(5 m) 4,900	4,862	4,850
	WALL MODULES	1. Mod. dim. (c/c)	2. Frame dim.	3. Exp. dim.
Height (mm):		2,500	2,412	2,400
Width, straight (mm):		490	452	440
		980	942	930
Width, curved (mm):		500	732x1,190	720x1,179
		1,000	1,502x1,190	1,490x1,179
Width, horizontal/diagonal (mm):		693	654	643
		1,386	1,348	1,336

MEASUREMENTS

Above are the panel dimensions, frame dimensions and exposed dimensions of fascia boards and wall panels.



WALL MODULE
Fabric-clad, plain
White (see colour samples for options)
Meas: 1 m. (c/c 980 mm)
Art.no 981100 **SEK 735**
Meas: 0,5 m. (c/c 490 mm)
Art.no 981110 **SEK 545**
45° DIAGONAL
Meas: 0,5 m. (c/c 693 mm)
Art.no 981185 **SEK 720**



WALL MODULE PLEXI
Meas: 1 m. (c/c 980 mm)
Tinted plexi Art.nr 981140
Opal Art.nr 981144
Clear Art.nr 981142
SEK 1,270
Meas: 0,5 m. (c/c 490 mm)
Art.no 981150 **SEK 810**
45° DIAGONAL
Meas: 0,5 m. (c/c 693 mm)
Art.no 981190 **SEK 1,160**



WALL MODULE DECORATIVE LATTICE
Metal
Meas: 1 m. (c/c 980 mm)
Art.no 981170 **SEK 1,135**
Meas: 0,5 m. (c/c 490 mm)
Art.no 981180 **SEK 810**
45° DIAGONAL
Meas: 0,5 m. (c/c 693 mm)
Art.no 981175 **SEK 1,050**



WALL MODULE
Pointed 45° diagonal
Meas: 1 m. (c/c 980 mm)
White: Art.no 981196 **SEK 805**
Grey: Art.no 981194 **SEK 805**
Plexi:
Tinted plexi Art.nr 981198
Opal Art.nr 981197
Clear Art.nr 981195 **SEK 1,160**



WALL MODULE VENETIAN BLINDS
White/Metal
Meas: 1 m
Art.no 981165 **SEK 810**



WALL MODULE CURVED
White (see colour sample for options)
Radius: 1 m
Art.no 981120 **SEK 1,315**



WALL MODULE CURVED
White (see colour sample for options)
Radius: 0,5 m
Art.no 981130 **SEK 1,095**



WALL MODULE CURVED PLEXI
Tinted, opal and clear
Radius: 1 m
Art.no 981160 **SEK 1,710**



WALL MODULE FOLDING DOOR
Light grey
Meas: 1 m
Art.no 981207 **SEK 1,140**



WALL MODULE CURTAIN MODULE
Colour and art.no see page 10
Meas: 1 m
Art.no 981271-1277 **SEK 580**



QUICK PANELS FOLDING WALL SYSTEM
Meas: 1 x 2 m
Blue Velcro fabric Art.no 981045
Grey Velcro fabric Art.no 981050
SEK 460

ACCESSORIES ALUMINIUM BUILDING SYSTEM

These accessories are intended for the aluminium building system.

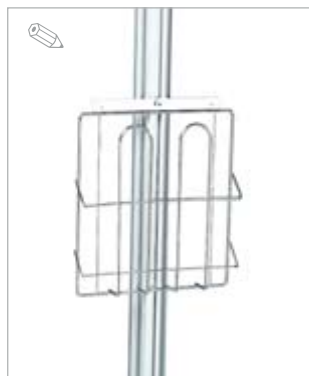

BROCHURE RACK
Chrome wire 1 x A4
Art.no 988720

SEK 120

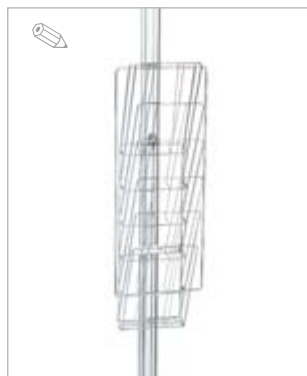

BROCHURE RACK
Chrome wire 6 x A4
Art.no 988730

SEK 240



CLOTHES HANGER
Wall-mounted
Art.no 988760

SEK 200



COMBINATION SHELF Straight or inclined. Meas: 960 x 300 mm
Art.no 988700 **SEK 240**
Extra shelf/wall module
Art.no 988701 **SEK 55 each**



PLASTIC BAG HOLDER
Art.no 988710

SEK 95



CLOTHES RAIL
Meas: 980 x 300 mm
Art.no 988751

SEK 250

WOOD BUILDING SYSTEM

Our wooden modules offer flexible solutions at a reasonable price. All walls are painted white as standard.



WALL MODULE

White (see page 10 for painting)
Meas: 1 x 2,5 m. Thickness: approx. 30 mm.
Art.no 211120 **SEK 455**



WALL MODULE

White (see page 10 for painting)
Meas: 0,5 x 2,5 m. Thickness: approx. 30 mm.
Art.no 211125 **SEK 300**



CURTAIN MODULE

Colour and art.no see page 10
Meas: 1 x 2,5 m
Art.no 213271-3277 **SEK 580**



FASCIA

White (see page 10 for painting)
Height: 30 cm. Length: max 4 m
Art.no 214210 **SEK 295**



WALL MODULE DOOR

A padlock can be bought at Service Center
White (see page 10 for painting)
Meas: 1 x 2,5 m Door opening approx. 85 cm
Art.no 212130 **SEK 670**

CARPENTRY WORK

Art.no 217700 **SEK 490/Hour**

ACCESSORIES WOOD BUILDING SYSTEM



CLOTHES CONSOLE Sloping
Complete with console rails
(excl. coat hanger)
Art.no 998620 **SEK 130**



WHITE SHELF* Straight or sloping.
Complete with console rails
Shelves not infinitely variable
Meas: 890 x 430 mm
Art.no 993660 **SEK 130**



STEEL SHELF* Straight or sloping.
Complete with console rails
Meas: 890 x 340 mm
Art.no 993665 **SEK 130**



CLOTHES RAIL
Complete with console rails
Meas: 890 x 300 mm
Art.no 998640 **SEK 250**



STEEL SHELF BLACK*
Meas: 890 x 340 mm
Art.no 993666 **SEK 240**

*MAX HEIGHT 2400 MM. MIN HEIGHT 750 MM

PAINTING

The following colours form our standard range for painting wooden walls. If you would like a different colour from those shown, order wall painting in special colours and quote the NCS number of the colour.

SOME COLOURS CANNOT BE REPRODUCED EXACTLY DUE TO TECHNICAL REASONS. CONTACT EXHIBITOR SERVICE FOR COLOUR SAMPLES.

Trend colours



BRIMSTONE NCS: S 0530-G90Y
Art.no 224189 **SEK 238/rm**



SKY NCS: S 1030-R80B
Art.no 224190 **SEK 238/rm**



LAVA NCS: S 6502-R
Art.no 224191 **SEK 238/rm**

Standard colours



BLUE NCS: S 5040-R90B
Art.no 224185 **SEK 238/rm**



RED NCS: S 4050-R
Art.no 224186 **SEK 238/rm**



DARK BROWN NCS: S 8005-Y80R
Art.no 224180 **SEK 238/rm**



BLACK NCS: 9000
Art.no 224170 **SEK 238/rm**



GREY NCS: S 4000-N
Art.no 224165 **SEK 238/rm**



YELLOW NCS: S 1060-Y10R
Art.no 224188 **SEK 238/rm**



BEIGE NCS: S 2010-Y10R
Art.no 224187 **SEK 238/rm**

PAINTING OF WALLS WITH SPECIAL COLOURS

Attach NCS no with order
Art.no 221100 **SEK 295/rm**

RESTORATION COST FOR OWN PAINTING

Own restoration not allowed
Art.no 221110 **SEK 145/rm**

EXTRA PAINT WORK

Art.no 227700 **SEK 495/hour**

FABRICS

Our fireproof fabrics are available in many different colours and can be used for several purposes, e.g. as drapes and fabric roofs. Drapes can for example be hung in front of the entrance to a store room. The fabric roof will be framed and mounted on support pillars. These pillars can be replaced by wires at an extra cost.



CURTAINS/ALUMINIUM SYSTEMS

Grey	Art.no 981276
Blue	Art.no 981274
Black	Art.no 981272
Green	Art.no 981275
Red	Art.no 981273
Yellow	Art.no 981277
Natural white	Art.no 981271
	SEK 565

CURTAINS/WOOD SYSTEMS

Grey	Art.no 213276
Blue	Art.no 213274
Black	Art.no 213272
Green	Art.no 213275
Red	Art.no 213273
Yellow	Art.no 213277
Natural white	Art.no 213271
	SEK 565

FABRIC CEILING

White	Art.no 241100
Black	Art.no 241110
	SEK 230/sqm

FABRIC/SQM*

Coloured fabric, please specify colour	Art.no 241191
	SEK 110/sqm
White fabric	Art.no 241190
	SEK 95/sqm

**COST FOR LABOUR MAY BE ADDED!*

CARPETS FOR HIRE

Carpets are laid in tiles of 50 x 50 cm. The laying of the carpet is included.

SOME COLOURS CANNOT BE REPRODUCED EXACTLY DUE TO TECHNICAL REASONS. CONTACT EXHIBITOR SERVICE FOR COLOUR SAMPLES.



BLACK
Art.no 231214 **SEK 90/sqm**



GRANITE
Art.no 231208 **SEK 90/sqm**



GREY
Art.no 231207 **SEK 90/sqm**



STONE PATTERN
Art.no 231460 **SEK 110/sqm**



LIGHT BLUE
Art.no 231202 **SEK 90/sqm**



BLUE
Art.no 231201 **SEK 90/sqm**



DARK BLUE
Art.no 231203 **SEK 90/sqm**



BRIGHT GREEN
Art.no 231215 **SEK 90/sqm**



GREEN
Art.no 231209 **SEK 90/sqm**



YELLOW
Art.no 231213 **SEK 90/sqm**



ORANGE
Art.no 231206 **SEK 90/sqm**



BRIGHT RED
Art.no 231205 **SEK 90/sqm**



RED
Art.no 231204 **SEK 90/sqm**



BEIGE
Art.no 231212 **SEK 90/sqm**



SAND
Art.no 231211 **SEK 90/sqm**



BROWN
Art.no 231210 **SEK 90/sqm**



SISAL/COCOS
Art.no 231465 **SEK 140/sqm**

FLOORING

The price includes the purchase and the laying of the floor, the hiring of foundation and edging.



OAK PARQUET
Art.no 233620 **SEK 475/sqm**



OAK LAMINATED
Art.no 233645 **SEK 395/sqm**



BIRCHWOOD PARQUET
Art.no 233640 **SEK 495/sqm**



BIRCHWOOD LAMINATED
Art.no 233650 **SEK 395/sqm**



RAISED FLOOR Excl. carpet and edging. Height approx. 5 cm
Art.no 233610 **SEK 195/sqm**
EDGING for raised floor.
Hiring of angle battens 25x25 mm aluminium.
Art.no 233903 **SEK 115/rm**



STAGE PODIUM Excl. carpet.
Height: 0,4 m, 0,6 m, 0,8 m, 1,0 m.
Art.no 215620 **SEK 220/sqm**

CARPETS FOR SALE

Needle felt carpets (rib) on a roll, 200 cm wide. The laying of the carpet and the removal of the protective plastic is included in the price.

SOME COLOURS CANNOT BE REPRODUCED EXACTLY DUE TO TECHNICAL REASONS. CONTACT EXHIBITOR SERVICE FOR COLOUR SAMPLES.



BLACK
Art.no 231246 **SEK 120/sqm**



DARK GREY
Art.no 231239 **SEK 120/sqm**



GRANITE
Art.no 231240 **SEK 120/sqm**



GREY
Art.no 231237 **SEK 120/sqm**

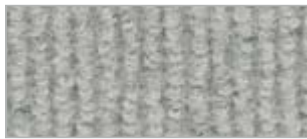

LIGHT GREY
Art.no 231238 **SEK 120/sqm**



DENIM BLUE
Art.no 231233 **SEK 120/sqm**

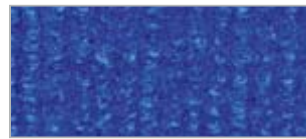

MEDIUM BLUE
Art.no 231231 **SEK 120/sqm**



DARK BLUE
Art.no 231232 **SEK 120/sqm**



LIGHT ORANGE
Art.no 231247 **SEK 120/sqm**



DARK ORANGE
Art.no 231236 **SEK 120/sqm**



RED
Art.no 231234 **SEK 120/sqm**



DARK RED
Art.no 231235 **SEK 120/sqm**



WHITE
Art.no 231243 **SEK 120/sqm**



YELLOW
Art.no 231245 **SEK 120/sqm**



GREEN
Art.no 231242 **SEK 120/sqm**



DARK GREEN
Art.no 231248 **SEK 120/sqm**



LILAC
Art.no 231249 **SEK 120/sqm**

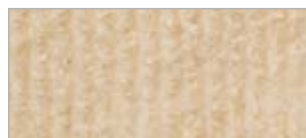

BEIGE
Art.no 231250 **SEK 120/sqm**

NEW!

Jigsaw Puzzle Carpet Ergo® – Avoid tired feet and backs in your stand.

Durable jigsaw puzzle carpets in sound-absorbing foam plastic, which provide flexible and elastic flooring. Simple to fit and clean, and can be reused several times both in – and outdoors. Light-weight material. Size carpet 60 x 60, edging 60 x 7 cm, 14 mm thick. Delivered in sqm with edging and corners. The price includes the laying of the carpet.

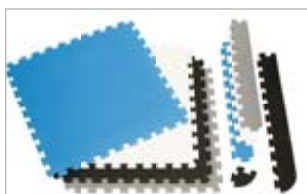

JIGSAW PUZZLE CARPET

White	Art.no 233000
Black	Art.no 233001
Blue	Art.no 233002
Grey	Art.no 233003
	SEK 245/sqm

Needle felt carpets (velour) on a roll, 200 cm wide. The laying of the carpet and the removal of the protective plastic is included in the price. Note: Limited stock

SOME COLOURS CANNOT BE REPRODUCED EXACTLY DUE TO TECHNICAL REASONS. CONTACT EXHIBITOR SERVICE FOR COLOUR SAMPLES.



BLACK
Art.no 231272 **SEK 145/sqm**



DARK GREY
Art.no 231273 **SEK 145/sqm**



MEDIUM GREY
Art.no 231264 **SEK 145/sqm**



LIGHT GREY
Art.no 231263 **SEK 145/sqm**



TURQUOISE
Art.no 231268 **SEK 145/sqm**



SAPPHIRE
Art.no 231266 **SEK 145/sqm**



MARIN
Art.no 231261 **SEK 145/sqm**



DARK BLUE
Art.no 231262 **SEK 145/sqm**



BEIGE
Art.no 231271 **SEK 145/sqm**



ORANGE
Art.no 231269 **SEK 145/sqm**



PINK
Art.no 231270 **SEK 145/sqm**



RED
Art.no 231265 **SEK 145/sqm**



GREEN
Art.no 231267 **SEK 145/sqm**

Other carpet types for sale on a roll, 200 cm wide. The laying of the carpet and the removal of the protective plastic is included in the price.

SOME COLOURS CANNOT BE REPRODUCED EXACTLY DUE TO TECHNICAL REASONS. CONTACT EXHIBITOR SERVICE FOR COLOUR SAMPLES.



ARTIFICIAL GRASS GREEN
Art.no 232525 **SEK 140/sqm**



RIPSEVELOUR, WHITE
Art.no 232600 **SEK 165/sqm**



PLASTIC CARPET Expo Durk
Art.no 232700 **SEK 140/sqm**



NEEDLE FELT CARPET Expo Stone
Art.no 232526 **SEK 165/sqm**

ACCESSORIES

THERE MAY BE DISCREPANCIES FROM THE PICTURE.



STANCHION WITH ROPE

Rope length 1,5m
Art.no 998707

SEK 430



CLOTHES RACK*

On castors. Length 1,530 mm
Art.no 998700

SEK 445



COAT STAND

Art.no 998360

SEK 180



PLANTS

Available for hire from our florist's at the East Entrance. For special flower arrangements, please contact info@hasselbyblommor.se



STORAGE SHELF 5 shelves

Meas: 860 x 330 x 1,760 mm
Wood: Art.no 993340

SEK 340



STORAGE SHELF 5 shelves

Meas: 600 x 1,480 mm
Steel: Art.no 993341

SEK 340



WALL MIRROR Light wooden frame*, white and black frame

Meas: 580 x 1,170 mm

Wooden frame: Art.no 994380

Black: Art.no 994379

White: Art.no 994378

SEK 335

SEK 335

SEK 335



FLOOR MIRROR Light wooden frame*

Meas: 400 x 445 x 1,640 mm

Art.no 994385

SEK 335



TABLE STAND

Stationary A4

Art.no 998265

SEK 85

*THERE MAY BE DISCREPANCIES



INFORMATION STAND Tower
Height: 1,050 mm
Art.no 998227

SEK 525



BROCHURE CAROUSEL
Black. On castors. Height: 1,430 mm
Art.no 998260

SEK 525



BROCHURE STAND Tower
Height: 1,930 mm
Art.no 998262

SEK 570

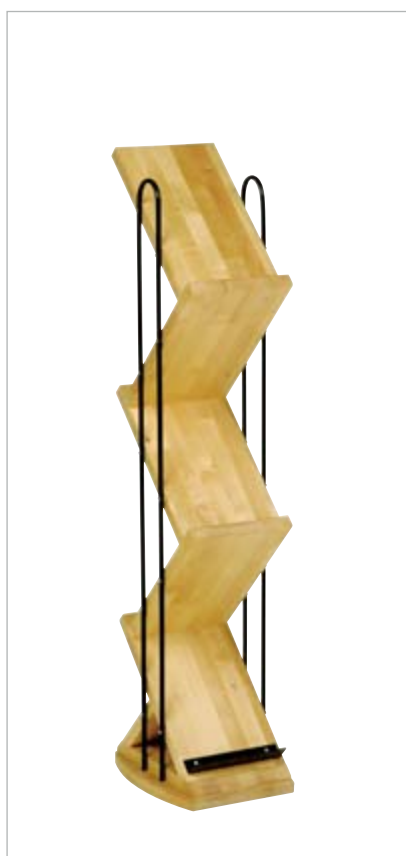

BROCHURE STAND Z
Height: 1 270 mm
Art.no 998263

SEK 695



BROCHURE STAND Ice
Height: 1 670 mm
Art.no 998264

SEK 695



BROCHURE STAND DNA
Height: 1,800 mm
White: Art.no 998261
Black: Art.no 998266

SEK 640
SEK 640

CHAIRS AND TABLES

THERE MAY BE DISCREPANCIES FROM THE PICTURE.



BAR STOOL Venus.
Seat height: 820 mm.
Art.no 997494 **SEK 280**



BAR STOOL Adea
Seat height: 690 mm.
Art.no 997486 **SEK 305**



BAR STOOL Snaps
Seat height: 800 mm.
Black: Art.no 997493 **SEK 335**
Beige: Art.no 997480 **SEK 335**



BAR STOOL Tribeca
Seat height: 600-800 mm
Art.no 997504 **SEK 260**



BAR STOOL Bistro
Seat height: 820 mm.
Art.no 997488 **SEK 335**



BAR STOOL Ansi
Seat height: 740 mm
Art.no 997489 **SEK 170**



BAR STOOL Diva
Seat height: 800 mm
Black: Art.no 997503 **SEK 335**
Beige: Art.no 997505 **SEK 335**



BAR STOOL los
Seat height: 850 mm
Art.no 997500 **SEK 335**



STOOL Marilyn
Seat height: 460 mm
Art.no 997487 **SEK 310**



CAFÉ-STYLE CHAIR Viking
Black. Seat height: 450 mm.
Art.no 997484 **SEK 290**



CHAIR Sting
Seat height: 450 mm
Art.no 997492 **SEK 335**



CAFÉ-STYLE CHAIR Klyka
Seat height: 460 mm.
Art.no 997479 **SEK 290**



CAFÉ-STYLE CHAIR Seat height: 460 mm
 White: Art.no 997496 **SEK 225**
 Solid oak: Art.no 997497 **SEK 225**



DIRECTOR'S CHAIR Seat height: 460 mm.
 Grey: Art.no 997482 **SEK 255**
 Black: Art.no 997483 **SEK 255**



CONGRESS CHAIR Ana
 Seat height: 460 mm
 Art.no 996836 **SEK 275**



FOLDING CHAIR
 Seat height: 450 mm.
 Art.no 997490 **SEK 120**



ARMCHAIR Comet
 Beige leather. Seat height: 460 mm.
 Art.no 997499 **SEK 775**



ARMCHAIR Exclusive
 Black leather. Seat height: 430 mm.
 Art.no 997485 **SEK 775**



ARMCHAIR Exclusive
 Beige. Seat height: 430 mm.
 Art.no 997498 **SEK 775**



STUDIO STOOL
 Beige leather. Seat height: 470 mm.
 Art.no 997501 **SEK 360**



TABLE Square
 Meas: 550x550 mm. Height: 450 mm
 Birch: Art.no 991441 **SEK 275**
 White: Art.no 991440 **SEK 275**
 Oak: Art.no 991439 **SEK 275**



CONFERENCE TABLE White tabletop, chrome legs
 Meas: 1500 x 800 mm. Height: 700 mm
 White: Art.no 991460 **SEK 535**
 Black: Art.no 991458 **SEK 570**
 Meas: 1200 x 700 mm. Height: 700 mm
 White: Art.no 991461 **SEK 440**
 Black: Art.no 991459 **SEK 455**

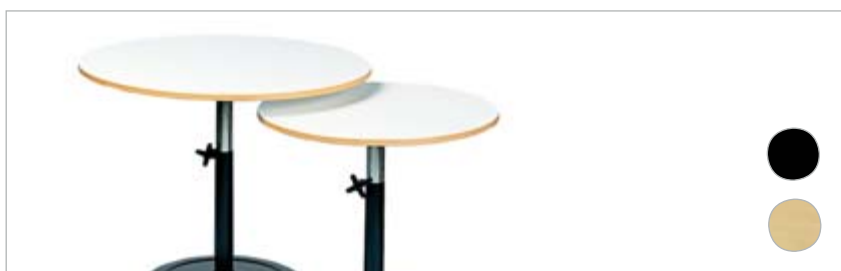
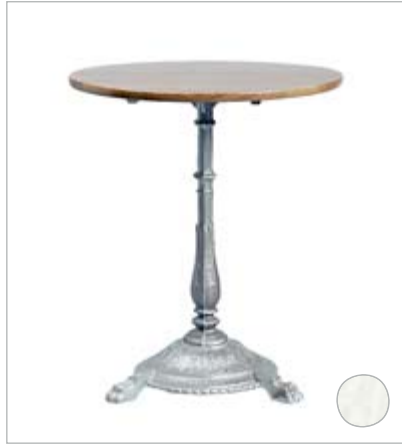

TABLE
 White. Meas: ø700 mm. Height: 550-890 mm. Art.no 991400 **SEK 350**
 White. Meas: ø900 mm. Height: 550-890 mm. Art.no 991420 **SEK 435**
 Birch. Meas: ø700 mm. Height: 550-890 mm. Art.no 991401 **SEK 465**
 Birch. Meas: ø900 mm. Height: 550-890 mm. Art.no 991421 **SEK 545**
 Black. Meas: ø700 mm. Height: 550-890 mm. Art.no 991402 **SEK 465**
 Black. Meas: ø900 mm. Height: 550-890 mm. Art.no 991422 **SEK 445**



CAFÉ-STYLE TABLE Klyka
 Meas: ø 700 mm. Height: 720 mm
 Beech: Art.no 991477 **SEK 535**



CAFÉ-STYLE TABLE Classic
 Meas: ø 600 mm. Height: 720 mm
 White: Art.no 991475 **SEK 460**
 Oak: Art.no 991476 **SEK 460**



TABLE Bistro
 Meas: ø 600 mm. Height: 500 mm
 Birch: Art.no 991455 **SEK 550**

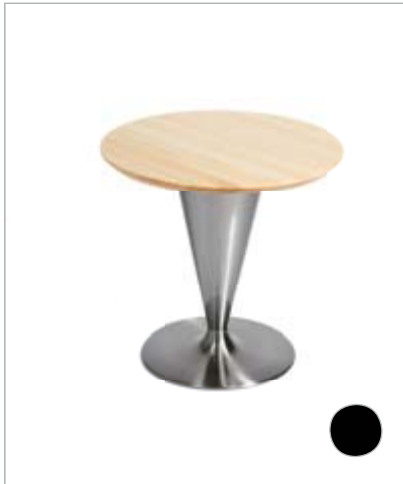
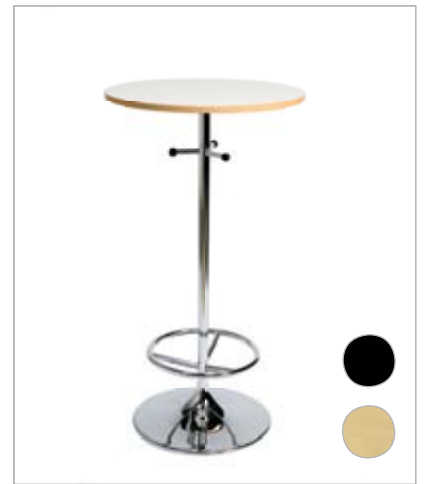

TABLE Snaps
 Meas: ø 600 mm Height: 570 mm.
 Birch: Art.no 991456 **SEK 650**
 Black: Art.no 991457 **SEK 650**



TABLE X-bone
 Meas: 725 mm x 700 mm x 600 mm
 Black: Art.no 991442 **SEK 555**



HIGH TABLE Pluto
 Meas: ø 600 mm Height: 1100 mm.
 White: Art.no 991450 **SEK 460**
 Birch: Art.no 991451 **SEK 570**
 Black: Art.no 991454 **SEK 570**

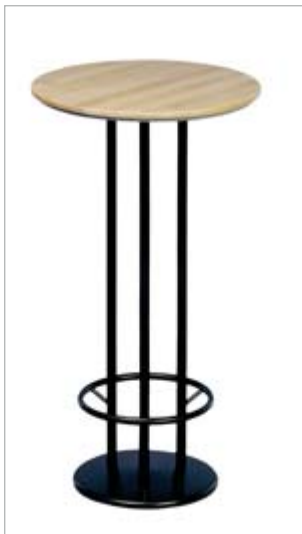

HIGH TABLE Bistro. Round
 Meas: ø 600 mm. Height: 1100 mm
 Birch: Art.no 991453 **SEK 640**



HIGH TABLE Bistro
 Meas: ø 600 mm. Height: 1100 mm
 Birch: Art.no 991452 **SEK 640**



HIGH TABLE Snaps
 Meas: ø 600 mm. Height: 1100 mm
 Birch: Art.no 991448 **SEK 665**
 Black: Art.no 991447 **SEK 665**



HIGH TABLE Ubbi
 Meas: ø 675 mm.
 Height: 720-1055 mm
 Beech: Art.no 991449 **SEK 510**

COUNTERS AND PODIA

Note that our lockable counters and podia cannot be considered to be security lockers/safes. All dimensions for counters and podia are given as width-depth-height. Max load on counters approx. 60 kg.

THERE MAY BE DISCREPANCIES FROM THE PICTURE.



BAR COUNTER
Meas: 1200 x 760 x 1120 mm
Art.no 992202 **SEK 1,515**



BAR COUNTER curved
(Excl. refrigerator)
Meas: 1172 x 1120 mm
Art.no 992222 **SEK 1,630**



CUPBOARD
Lockable top and bottom.
Meas: 960 x 350 x 750 mm
Art.no 992203 **SEK 1,115**



GLASS COUNTER White
Lockable sliding door at the rear.
Meas: 960 x 600 x 1040 mm
Art.no 992190 **SEK 1,355**



GLASS COUNTER Birch
Lockable sliding door at the rear.
Meas: 960 x 600 x 1040 mm.
Art.no 992191 **SEK 1,725**



DEMONSTRATION COUNTER White
Lockable sliding door at the rear.
Meas: 960 x 600 x 1040 mm
Art.no 992195 **SEK 1,085**



DEMONSTRATION COUNTER Birch
Lockable sliding door at the rear.
Meas: 960 x 600 x 1040 mm
Art.no 992196 **SEK 1,425**



INFORMATION COUNTER NARROW
Internal shelf.
Meas: 960 x 600 x 1040 mm
White: Art.no 992197 **SEK 1,010**
Birch: Art.no 992198 **SEK 1,110**



INFORMATION COUNTER NARROW
Aluminium. Internal shelf.
Meas: 960 x 600 x 1000 mm
Art.no 992123 **SEK 1,110**



INFORMATION COUNTER White
(Left section) Internal shelf (height 700 mm).
Meas: 1500 x 600 x 1040 mm
Art.no 992200 **SEK 1,335**



INFORMATION COUNTER Birch
Internal shelf (height 700 mm).
Meas: 1500 x 600 x 1040 mm
Art.no 992201 **SEK 1,705**



CURVED COUNTER SECTION (Left section)

White. Closed
Meas: 600 x 600 x 1040 mm
Art.no 992210

SEK 665



CURVED COUNTER SECTION Birch

Closed.
Meas: 600 x 560 x 1040 mm
Art.no 992211

SEK 965



INFORMATION COUNTER White

Internal shelf (height 700 mm).
Outer radius: 1090 mm
Art.no 992220

SEK 1,430



INFORMATION COUNTER Birch
Internal shelf (height 700 mm). Outer
radius: 1090 mm

Art.no 992221 **SEK 1,810**



QUICK COUNTER (Right section)
White. Sliding doors, storage space
with shelf.

Meas: 960 x 500 x 1040 mm.
Art.no 992230 **SEK 730**



QUICK COUNTER (Right section)
Birch. Sliding doors, storage space
with shelf.

Meas: 960 x 500 x 1040 mm.
Art.no 992231 **SEK 915**



CURVED QUICK COUNTER (Left
section) White. Closed.

Radius: 500 mm. Height: 1040 mm
Art.no 992235 **SEK 600**
Birch: Art.no 992236 **SEK 775**



COMPUTER QUICK COUNTER White
Internal shelf

Meas: 1000 x 930 x 1040 mm
White: Art.no 992237 **SEK 795**
Birch: Art.no 992238 **SEK 990**



GLASS CUBE White. Lockable
Meas: 500 x 500 x 1040 mm.
Art.no 992175 **SEK 700**



GLASS CUBE Birch. Lockable
Meas: 500 x 500 x 1040 mm.
Art.no 992176 **SEK 800**



REPLY SLIP BOX White
Meas: 500 x 500 x 1040 mm
White: Art.no 992275 **SEK 490**
Birch: Art.no 992276 **SEK 590**



GLASS CABINET White
Incl. light. 2 shelves. Lockable
Meas: 960 x 470 x 1850 mm
Art.no 992180 **SEK 2,250**



GLASS CABINET Birch
Incl. light. 2 shelves. Lockable.
Meas: 960 x 470 x 1850 mm
Art.no 992181 **SEK 2,465**



DISPLAY CABINET Black. Lockable
Incl. light.
Meas: 800 x 400 x 1800 mm
Art.no 992184 **SEK 1,965**



DISPLAY CABINET White
Incl. light. Lockable drawer unit.
Meas: 470 x 470 x 1850 mm
Art.no 992182 **SEK 1,750**



DISPLAY CABINET Birch
Incl. light. Lockable drawer unit.
Meas: 470 x 470 x 1850 mm
Art.no 992183 **SEK 1,965**



COMPUTER STAND
Adjustable height
Meas: 900 x 660 x 720-1230 mm
Art.no 992725 **SEK 865**



LAPTOP TABLE
Meas: 590 x 560 x 1110 mm
Art.no 992713 **SEK 670**



COMPUTER PODIUM
Meas: 700 x 650 x 1270 mm
White: Art.no 992715 **SEK 845**
Birch: Art.no 992716 **SEK 1,035**



DRAWER UNIT Lockable sliding door at the rear.
Meas: 960 x 470 x 700 mm
White: Art.no 992110 **SEK 1,005**
Birch: Art.no 992111 **SEK 1,035**



STAND FOR TV AND VIDEO
Excl. TV and video.
Meas: 600 x 450 x 1150 mm
White: Art.no 992710 **SEK 410**
Birch: Art.no 992711 **SEK 515**



PODIUM Birch
Meas: 500 x 500 x 400 mm
Art.no 995126 **SEK 370**
Meas: 500 x 500 x 600 mm
Art.no 995136 **SEK 420**



PODIUM
Meas: 500 x 500 x 400 mm
Art.no 995125 **SEK 270**
Meas: 500 x 500 x 600 mm
Art.no 995135 **SEK 315**

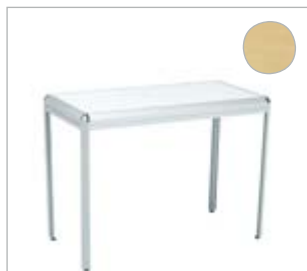

BENCH
Meas: 960 x 470 x 700 mm
White: Art.no 991100 **SEK 395**
Birch: Art.no 991101 **SEK 430**



PODIUM
Meas: 500 x 500 x 800 mm
Art.no 995145 **SEK 350**
Meas: 500 x 500 x 1020 mm
Art.no 995162 **SEK 395**



PODIUM Birch
Meas: 500 x 500 x 800 mm
Art.no 995146 **SEK 460**
Meas: 500 x 500 x 1020 mm
Art.no 995163 **SEK 500**



PODIUM
Meas: 1000 x 500 x 400 mm
White: Art.no 995172 **SEK 395**
Birch: Art.no 995173 **SEK 500**

WATER, COMPRESSED AIR AND KITCHENETTE

On this page you will find the most necessary things for your kitchenette. A Coffee-maker can be bought at our Service Center. Please complete a drawing to scale when ordering water, drainage and compressed air.

ADDITIONAL PLUMBING WORK
Art.no 259700 **SEK 490/HOUR**



WATER HEATER
Incl. electricity.
30 litres
Art.no 252200 **SEK 2,380**



WATER & DRAINAGE OUTLET
R15 external male thread 3kg of pressure/min.
+draining outlet ø 50 mm
Art.no 251100 **SEK 3,080**



WATER OUTLET
R15 external male thread
3 kg of pressure/min
Art.no 251110 **SEK 1,665**



COMPRESSED AIR TUBE
We guarantee and deliver max 6 bar pressure.
R15 internal male thread
Art.no 261100 **SEK 1,665**



SINK
Incl water and drainage.
Meas: 1000 x 600 x 900 mm
Art.no 252301 **SEK 4,145**



SINK Incl water and drainage.
Mounted on wooden wall
Panel Meas: 500 x 1200 mm
Art.no 252316 **SEK 3,695**



REFRIGERATOR 120–140 litres
Incl. connection, 24h
Meas: 550 x 600 x 850 mm
Art.no 994330 **SEK 1,450**



STORAGE SHELF
5 shelves
Meas: 860 x 330 x 1760 mm
Art.no 993340 **SEK 340**



WASTE CONTAINER*
Excl. emptying
100 litres with 5 refuse sacks
Art.no 994370 **SEK 175**

*APPEARANCE MAY VARY

ELECTRICITY AND LIGHTING

Good lighting makes your stand more attractive and focuses on the elements you want to highlight. You can order building and night electricity at an extra cost. Just remember to specify this in your order.

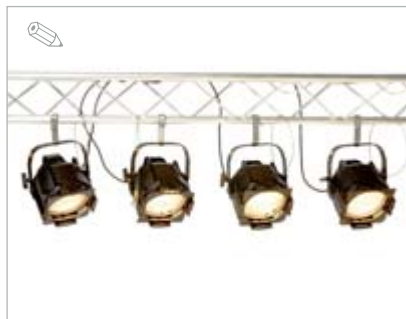

LIGHT GIRDER Width 4 m. Mounting and connection incl. For alternative lighting solutions for your stand, contact Exhibitor Service on +46 8 749 44 44 or e-mail: us@stofair.se
Art.no 333530 **SEK 6,085**



CEILING SPOTLIGHT \varnothing 410 mm. 250W
Incl. assembly and connection
Light: \varnothing 5 m from a height of 4 m
Art.no 413500 **SEK 800**



SPOTLIGHT Long arm 75W. Meas: 350 mm
Clamp width 35–40 mm. Mounted on wood.
Incl. assembly. Excl. connection
Art.no 413101 **SEK 240**
SPOTLIGHT Short arm 75W.
Clamp width 35–40 mm. Mounted on wood.
Incl. assembly. Excl. connection
Art.no 413100 **SEK 240**



LIGHT TOWER with 4 x 300W light fittings
Height: max 4 m. Incl. connection
Art.no 333600 **SEK 3,845**



SPOTLIGHT Long arm 75W
Only for Aluminium Building System
Length: 350 mm
Incl. assembly. Excl. connection
Art.no 984620 **SEK 235**
SPOTLIGHT Short arm 75W
Incl. assembly. Excl. connection
Art.no 984615 **SEK 235**



SPOTLIGHT Long arm
Only for Aluminium Building System
Length: 400 mm.
Incl. assembly. Excl. connection
Art.no 984700 **SEK 285**



ELECTRICITY CONNECTION 230V, 10A, max 2000W
Art.no 411220 **SEK 720**



POWER OUTLET 3-phase, max 10,6 kW, 16 A
Art.no 412316 1–5 days **SEK 1,585**
Art.no 412318 6– days **SEK 2,015**
POWER OUTLET 3-phase, max 16,5 kW, 25 A
Art.no 412325 1–5 days **SEK 2,325**
Art.no 412327 6– days **SEK 3,110**
POWER OUTLET 3-phase, max 41,6 kW, 63 A
Art.no 412363 1–5 days **SEK 4,535**
Art.no 412365 6– days **SEK 6,720**
POWER OUTLET 3-phase, max 82,5 kW, 125 A
Art.no 412125 1–5 days **SEK 7,490**
Art.no 412127 6– days **SEK 12,550**

ELECTRICITY FROM CEILING

10 amp. 1-phase	Art.no 411810	SEK 1,240
16 amp. 1-phase	Art.no 411815	SEK 1,850
16 amp. 3-phase	Art.no 412820	SEK 2,335
25 amp. 3-phase	Art.no 412825	SEK 2,995
63 amp. 3-phase	Art.no 412830	SEK 5,400

WORKING POWER

10 amp. 1-phase	Art.no 411002	SEK 410
16 amp. 1-phase	Art.no 411005	SEK 620
25 amp. 3-phase	Art.no 411006	SEK 620

24H ELECTRICITY

10 amp. 1-phase	Art.no 411221	SEK 1,085
16 amp. 1-phase	Art.no 412760	SEK 2,165
25 amp. 3-phase	Art.no 412762	SEK 3,165

FUSE BOX

16 amp. 1-phase	Art.no 414643	SEK 840
25 amp. 3-phase	Art.no 414644	SEK 1,200

AV TECHNOLOGY, SOUND, IMAGES, DATA, TELEPHONY

Choose from a selection of the first-class audiovisual technology. Please visit the Exhibitor Shop at www.stockholmsmassan.se "For Exhibitors", where you will find all the latest prices and order directly online. You can also contact Exhibitor Service for prices, quotations and advice.



TV PLASMA 16:9 WIDE SCREEN
 Excl. floor stand
 42" incl. speakers (res. 1024x768)
 Art.no 337422 **SEK 3,500**
 50" incl. speakers (res. 1280x768)
 Art.no 337423 **SEK 4,500**
 61" incl. speakers (res. 1365x768)
 Art.no 337424 **SEK 7,000**
 84" incl. speakers and stand
 c/c 2500 mm 706x960
 Art.no 337425 **SEK 24,200**

TV LCD 16:9 WIDE SCREEN
 32" incl. speakers (res. 1365x768)
 Art.no 337440 **SEK 2,500**
 40" incl. speakers (res. 1365x768)
 Art.no 337443 **SEK 3,000**
 42" built-in speakers (res. 1920x1080)
 Art.no 337441 **SEK 4,500**
 52" built-in speakers (res. 1920x1080)
 Art.no 337442 **SEK 5,900**

TV PLASMA 4:3
 37" incl. speakers (res. 1024x768)
 Art.no 337421 **SEK 4,500**

ACCESSORIES PLASMA/LCD TV
 Floor stand on hire of Plasma/LCD TV, height overall 170-180 cm. Note: Only available for TVs rented from Stockholm International Fairs.
 Art.no 337791 **SEK 700**
 DVD player for TVs rented from Stockholm International Fairs
 Art.no 337510 **SEK 350**



TV PLASMA 42" INCL. FLOOR STAND
 Built-in DVD and speakers (c/c1450 mm)
 Art.no 337455 **SEK 3,500**



COMPUTERS
 PC Desktop, minimum specification: PVI 640, 1Gb RAM, 60Gb HD, DVD. Monitor or Office 2007 Pro not incl.
 Art.no 338100 **SEK 1,580**

PC Desktop, minimum specification: PIV Core 2 Duo, 2Gb RAM, 60Gb HD, DVD/-CD-Rw. Incl. Office 2007 Pro. Monitor not incl.
 Art.no 338101 **SEK 2,640**



COMPUTER MONITORS
 Flat TFT 17" 5:4 1280x1024
 Art.no 338337 **SEK 890**
 Flat TFT 19" 5:4 1280x1024
 Art.no 338331 **SEK 1,480**
 Flat TFT 20" 4:3 1600x1200
 Art.no 338333 **SEK 2,680**

COMPUTER MONITORS WIDE SCREEN
 Flat TFT 20" 16:10 1680x1050
 Art.no 338338 **SEK 2,280**
 Flat TFT 24" 16:10 1900x1200
 Art.no 338332 **SEK 2,680**



PC LAPTOP
 PC LapTop, minimum specification: T7200, 1Gb RAM, 40 Gb HD, DVD/CD-Rw, 1280x800. Incl. Office 2007 Pro.
 Art.no 338200 **SEK 3,300**

PC LapTop, minimum specification: 1,4 GHz Celeron-M, 512Mb RAM, 30Gb HD, DV /CD-Rw, 1024x768. Office 2007 Pro not incl.
 Art.no 338201 **SEK 2,490**



LASER PRINTER COLOUR

A4, USB, RJ45 10/100 Mb Ethernet
 Art.no 338510 **SEK 3,395**
 With transcription of more than 100 papers,
 extra cost SEK 10 per transcription.



LASER PRINTER B/W

A4, USB, RJ45 10/100 Mb Ethernet
 Art.no 338500 **SEK 1,440**



ANTENNA OUTLET

Com Hem standard range
 Art.no 339100 **SEK 2,440**

TELEPHONE CONNECTION Incl./excl. telephone

SEK 1/charge unit
 Art.no 311100 **SEK 975**

FAX Incl. installation

Art.no 338600 **SEK 2,445**

PAPER to the fax/printer (500 sheets A4)

Art.no 338000 **SEK 80**



INTERNET CONNECTIONS

IP INTERNET CONNECTION

10 base T, RJ45 male IP 10 Mbps (dynamic net)
 Art. no 332710, First **SEK 2,975**
 Art. no 332711, Additional/each **SEK 1,975**

You can hire what you need from us or bring along your own computer with the 10 base T network card. Configure the computer for DHCP (automatic assignment of IP addresses). E-mail is only available through webmail or web-access to your own e-mail server. Please note that our Internet connection has no Firewall. You are responsible for your computer's protection when it comes to Antivirus/Firewall etc. Make sure that you have the latest Service Pack etc. from www.windowsupdate.com. Note that computers with a virus can cause problems when you are back behind your own Firewall in the office.

WIRELESS INTERNET CONNECTION

Wireless Internet connection cannot be pre-booked. Available for purchase from the Service Centre.

Per computer and event **SEK 1,000**

Wireless connection is valid from the first day you move in, throughout the event and while you move out. Connect using your own laptop computer or other wireless device, e.g. PDA or mobile phone. Our wireless network is a public network for our exhibitors. Contact your own IT Support for guidance on how to connect. We cannot provide support regarding settings on your own equipment. Follow the instructions on site regarding which network to connect to. E-mail is only available through webmail or web-access to your own e-mail server. We have no support for external SMTP servers. Our Internet connection has no Firewall. You are responsible for your computer's protection when it comes to Antivirus/Firewall etc. Note that computers with a virus can cause problems when you are back behind your own Firewall in the office.



SOUND SYSTEM Compact

Incl. 1 microphone
 Art.no 334140 **SEK 920**

MUSIC SYSTEM

Incl. microphone and CD-player
 Art.no 334130 **SEK 1,630**



CORDLESS NECK-MIKE

For Sound System 334140
 Wireless
 Art.no 334630 **SEK 1,275**

GOODS

If you need to load/unload more than 1,000 kg or 4 cbm, you must book time for a forklift truck. This will enable us to provide you with a better service and you don't have to wait in line for help with unloading your goods. Make it really easy by using the "Door-Stand-Door" service. Please find the order form for "Door-Stand-Door" and time booking at www.stockholmsmassan.se.



UNLOADING GOODS BY FORKLIFT
Art.no 461509-20 Lift per pallet **SEK 170**

PACKAGE DELIVERY
Max 50kg/ shipment
Art.no 461700 **SEK 65**

STORAGE OF EMPTY PACKAGING
incl. handling/cubic metre
(min. charge 2 cubic metre)
Art.no 471300 **SEK 190**

NOTE: CANNOT BE PRE-BOOKED

GOODS STORAGE/SQM/5 DAYS
Art.no 471310 **SEK 200**
Transportation excluded

Separate lifting insurance can be requested from our logistics department and is debited at 0.15% of the full value of the goods. NSAB-2000 (Nordiskt speditörsförbund Allmänna Bestämmelser) applies to all assignments, with the exception of paragraphs 6 and 27 C3. A copy of NSAB-2000 can be requested.

GOODS ADDRESS:
Stockholmsmässan/
Stockholm International Fairs
Godsmottagningen
"Event name"
"Company"
"Stand number"
Parkeringsvägen 10
125 80 Stockholm (Älvsjö), Sweden

HANGING WIRES

We can hang wire and telpher for all your constructions and signs. Please use the order form and send us your order well in advance of the exhibition. Remember to apply for permission for stands with increased exposure space over the height of 2.5 m.

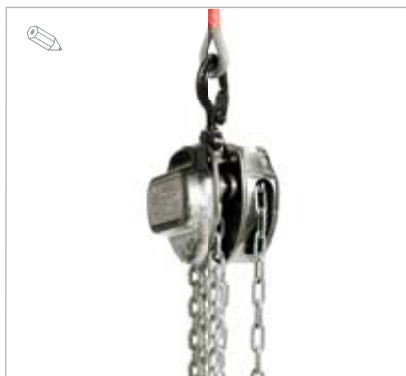

TELPER
Incl. wiring, mantling and safety device
Art.no 292162 **SEK 1,630**

WIRE SUPPORTING REPLACED POLES
Art.no 291120 **SEK 1,010**



WIRES
Hanging from ceiling.
Art.no 291103 **SEK 1,010**
Wires 3 mm 1-50 kg
Art.no 291106 **SEK 1,010**
Wires 6 mm 51-150 kg

WIRE MOUNTING of customer's own product,
incl. platform, min. charge 0.5 hours.
Art.no 291125 **SEK 1,020/hr**



WIRE-SUSPENDED PROJECTOR SHELF
Excl. electricity
Art.no 295250 **SEK 950**
10 amp to projector shelf **SEK 345**

Wires may not be performed during the official moving in period. Note that orders placed during the building up period will be charged an additional fee of 25%. The cost for fitting/removing wires debited once the fair is over. Exact positioning of wires cannot be guaranteed because of the roof's technical construction. The exhibitor is responsible for ensuring that Stockholm International Fairs' security measures regarding loading are followed. In the interest of safety, Stockholm International Fairs reserves the right to increase the number of wires and charge the relevant exhibitor. In addition to the hourly rate there may also be additional costs for special units. The exhibitor pays a special fee for the construction of the stand and exhibition space for advertising that exceeds the fair's maximum height of 2.5 m.

EXHIBITION SPACE > 2,5M
Art.no 15500 **SEK 5,000**

AT YOUR SERVICE



HOSTS AND HOSTESSES

We can provide services including language interpretation, demonstration of products and services, serving of refreshments, as well as various other assistance which may be required during the course of the fair. Should you also need assistance with packing or unpacking your products before or after the fair, we can also help you to arrange this. Minimum 4 hour/day.

Art.no 381010

SEK 290-490/hour



SECURITY PERSONNEL/ FIRE OFFICER

Staff for you stand. Minimum 4 hour/day.

Art.no 421100

SEK 505/hour



PHOTOGRAPHER

Please contact Exhibitor Service if you need photos of your stand. See General Rules on page 32.



CATERING

To order stand catering, please contact Mäsrestauranger +46 8 727 72 40 or e-mail: montercatering@restofair.se



TRAVEL & ACCOMMODATION

Need information regarding where to stay in Stockholm? Please contact Stockholm Exhibition travel on +46 8 736 03 33. For more information please visit www.stockholmsmassan.se



STAND CLEANING

Stand cleaning

Art.no 431000

SEK 8 sqm/day

Mopping

Art.no 432015

SEK 8 sqm/day

Additional waste collection

Art.no 434065

SEK 505/hour



PARKING

Parking permits can be bought at Service Centre and at the Information Desk. However our parking spaces tend to get occupied quickly, so we recommend taking the commuter train. It takes only 10 minutes from the centre of Stockholm to Älvsjö station.



ON SITE SERVICES

Cash point, newsagent, storage boxes, florist, First Aid and nursery room are available on site. Please do not hesitate to contact our staff if you need help.



RESTAURANTS

Welcome to eat in one of our twelve restaurants. The range covers everything you need. For more information, please visit www.restofair.se or contact us on one of the following telephone numbers:

The Garden Restaurant table reservation:

+46 8 727 72 60

Stand Catering: +46 8 727 72 40

PHOTOGRAPHER: JOAKIM KRÖGER

GRAPHIC DESIGN

Make your stand unique with the help of the Graphics Department. Drop-papers, banners, illuminated signs and transparencies are just some of the products you can choose between. If you have an idea of how you want your stand to look, or a draft stand drawing, please contact Exhibitor Service.

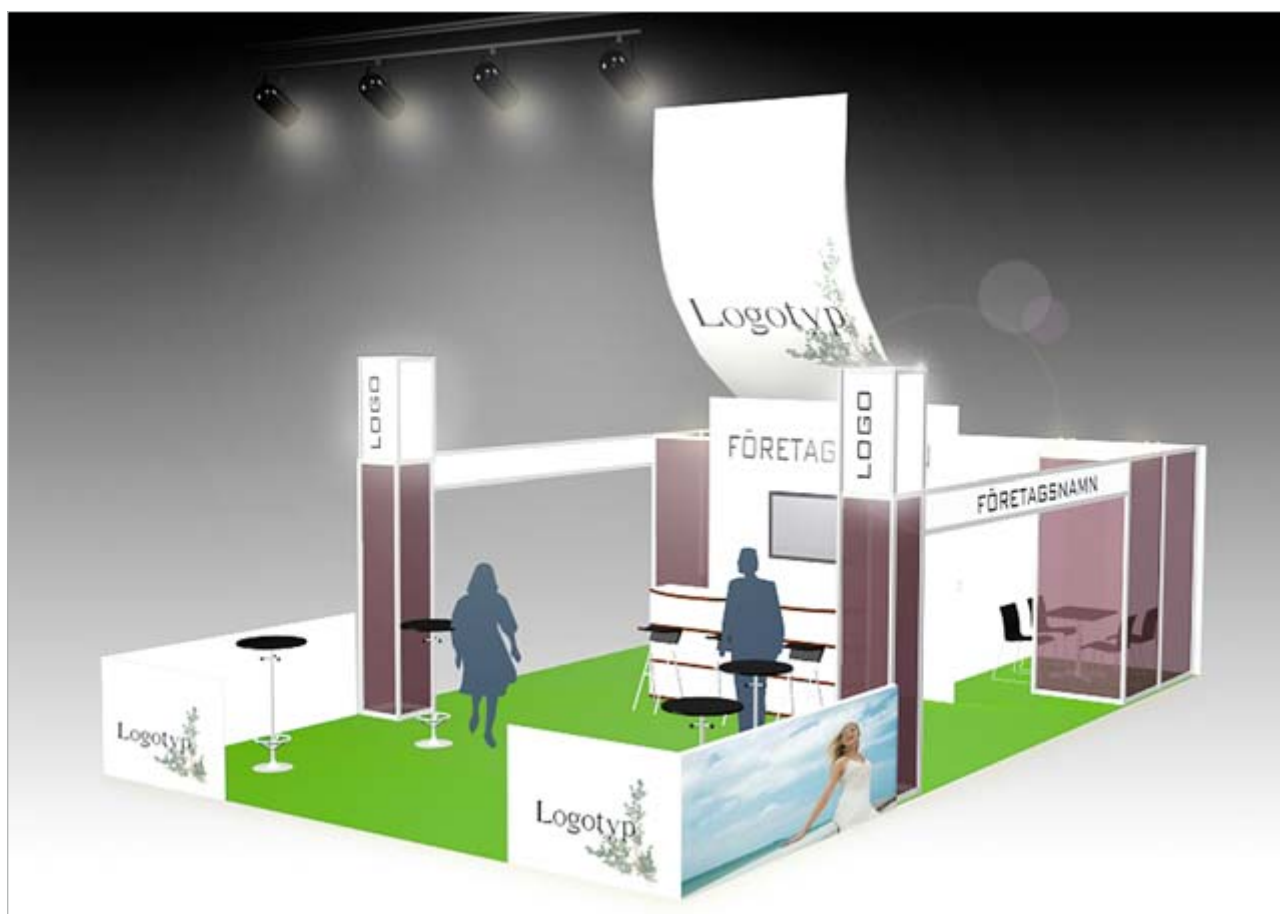

FASCIA Art.no 970065 **SEK 50/letter**
FASCIA LOGOTYPE* Art.no 970070 **SEK 505/one colour**
 + SEK 100/additional colour

** THE COST FOR ORIGINAL ARTWORK MAY BE ADDED.*



STAY COMFORTABLY CLOSE TO THE FAIR

Rica Talk Hotel – the perfect hotel for you who wants to relax after a successful working day at Stockholm International Fairs. Right next to the exhibition halls we have gathered 248 comfortable rooms, luxurious suites, trendy bars, restaurants, a gym and sauna, as well as meeting opportunities for 2 to 1,000 people. Add our exclusive top-floor department Top Talk with an uninterrupted view from the 18th floor, and you will understand that the interest is huge. In other words, here you have everything you need to be able to enjoy your time by yourself or together with your clients.

Call us and book your room today. Or visit us on www.rica.se/talk.

INFORMATION AND BOOKING

Telephone: +46-8-588 820 00

E-mail info.talk@rica.se



Rica Talk Hotel

ATTRACTIVE ADVERTISING LOCATIONS AT LOW CONTACT COST

To win the tough competition for attention at a site where an entire industry is gathered is a matter of declaring that you exist. For a very low contact cost you can:

- Attract visitors
- Attract attention and create a foundation for recognition
- Increase interest in your company and brand name
- Attain visibility at strategically selected locations
- Reach the right target group.



First to be seen

OUTDOOR SIGNS

By means of outdoor signs (sized 1190 x 1750 mm) you can welcome visitors to your stand or take the opportunity to advertise a new product visible right after the visitors get off the commuter train and walk towards Stockholm International Fairs. There are over 30 locations around the entire site.

PRICE 3,600 SEK per location



Gigantic hangings face the busy road

FAÇADE HANGINGS

There are locations for 4 jumbo sized fabric hangings on the façade facing the road. These hangings measure approximately 7x10 metre. The hangings are lit up by floodlights after dark and attract an enormous amount of attention from the motorists on the road. An excellent opportunity for those who really want to be seen!

PRICE 25,000 SEK per location



Eye-catching floor stickers

FLOOR STICKERS

Expose your brand name and products or welcome your customers with eye-catching floor stickers (sized 1 x 1.5 metres) in the entrance halls. The stickers are very hard wearing and will stay in good and fully legible condition for many days. There are eight sticker locations available in the main entrance hall and four at the East Entrance.

PRICE 3,100 SEK per location



Exclusive attention for your message

SIGNS IN PUBLIC TOILETS

Most fair visitors spend a quiet 5-10 minutes or so in the toilet at some time. We offer you access to some 150 sign locations (foolscap size/A4) on the inside of the toilet doors.

PRICE EXAMPLE:

13 signs: **8,000 SEK**



Attract visitors to your own website

ADVERTISING BANNER

Most visitors begin their visit at the fair website. Make use of this and insert an advertising banner with a link to your own website. Your advertisement will be displayed for up to 3 months. Space is limited, so book in good time.

PRICE 4,200 SEK per space

In addition to the above products we can provide estimates for customised solutions for other activities and advertising exposure. We wish to make your advertising message as flexible as possible and will be pleased to discuss new ideas.

ALL PRICES EXCLUDING VAT. POSSIBLE ADDITIONAL CHARGES FOR PRODUCTION COSTS AND 8% ADVERTISING TAX. THE RANGE OF ADVERTISING LOCATIONS VARIES ACCORDING TO CONTENTS OF THE FAIR.

VISITOR REGISTRATION

After some hectic days the fair has ended. However, this is only the beginning of a long process. Using the visitor badge scanner service makes the follow-up easier. You will not need the business cards and all the notes, you can just focus on the meeting. With the visitor registration you can collect the information needed from the visitor in an easy and flexible way. The follow-up work can start without delay. Knowledge about the customers' demands can be profitable.



- Read the visitor information with a bar code reader and combine with your own specified codes.
- Collect your own reports on the Internet every day during the exhibition.
- When a new reader is fetched in the morning, you will have a clear summary of the visits to your stand the day before.
- You will get a total summary on the Internet after the fair

START-UP PACKAGE
Art. no 10301

SEK 1,995

INSURANCE

The insurance cover is important when participating in an exhibition. Ordinary insurance policies do not normally cover exhibiting at fairs. Separate transport and exhibition insurance is often very expensive and yet provides less cover than the exhibition insurance we offer. Transport companies' liability is also very limited. Together with the insurance provider If Skadeförsäkring, Stockholm International Fairs has come up with the most favourable and simple exhibitors' insurance on the market, which is also mandatory for all those exhibiting at Stockholm International Fairs.

THIS IS WHAT OUR INSURANCE INCLUDES:

- Your goods are fully insured during transport to and from the exhibition, incl. during loading and unloading.
- Your goods are fully insured at the exhibition centre during the exhibition, incl. during moving in and moving out.
- All transport to and from the exhibition within EU/EFTA countries is covered. For insurance policy holders outside the EU/EFTA, insurance is only valid within the exhibition centre.
- You will also receive protection for your personal luggage, plus health and accident cover.
- Includes Liability insurance

- The excess is SEK 1,000 per/incident of loss or theft. For claims resulting from burglary and theft from a vehicle/ trailer owned by the insured, the excess is 20% of the lost amount or a minimum of SEK 5,000, whichever amount is higher.
- Additional costs incurred as a result of damage include up to 10% of the insurance value.
- This insurance is available to exhibitors, co-exhibitors and companies represented on your stand.

FOR TERMS OF INSURANCE, SEE PAGE 35.

TECHNICAL INFORMATION

1. Instructions and rules for stand construction

GENERAL RULES

- To create an open environment at the fair, only 1/3 of each stand's side facing an aisle may be covered by a wall.
- Building work or the putting up of decorations, signs or lighting over aisles is not permitted.
- Stockholm International Fairs make regular safety inspection rounds before and during every fair. Stockholm International Fairs' evacuation routes and fire doors (including those outside), fire equipment, alarm buttons and signs must NEVER be obstructed, blocked or concealed. Stockholm International Fairs has the right to take down or change constructions as well as remove goods that are blocking the evacuation and transport routes.
- Podia, stages and catwalks that exceed 60 cm in height must have a handrail of 110 cm in height.
- Floor anchorage is permitted for exhibitors on approval by Stockholm International Fairs. Exhibitors are responsible for restoring to original condition. If not restored, exhibitors will be debited. PLEASE NOTE, anchoring must not be closer than 1 meter from the service channel.
- All work which has an effect on the actual property of Stockholm International Fairs must only be carried out by people employed by the Stockholm International Fairs. Examples of this include the hanging of wires in ceilings, anchoring machinery to the floor, fixing into pillars or joists, and connecting water and electricity in floor channels.
- Climbing on any part of the stand construction is strictly prohibited.
- In order to avoid high noise levels, only rubber mallets or the equivalent may be used when mounting lighting girders.
- When using saws, sanding and polishing machines etc. a suction device for shavings must be attached to this type of equipment.
- Children and young people under the age of 16 are not allowed on Stockholm International Fairs premises at any time when construction or dismantling of exhibitions or congresses is taking place, neither alone, nor accompanied by an adult, as the exhibition halls are regarded as a building site.
- In accordance with Swedish legislation, smoking is not permitted anywhere on the site.
- In accordance with Swedish alcohol laws, all alcohol served must be purchased by the holder of the dispensing permit at Stockholm International Fairs, Mässrestauranger AB. Mässrestauranger AB is therefore in charge of serving alcoholic beverages on the premises. Exhibitors who are planning to, or wish to serve alcoholic beverages must contact Mässrestauranger AB, telephone +46 8 727 72 02 for assistance with the arrangements.
- All playing of music, showing of films or suchlike in stands, conference premises or any other place must be done in accordance with the applicable Copyright Act.
- Photographs may be taken 1 hour before the trade fair opens, and during the fair's opening hours. Photographs can be taken at other times by special agreement and with additional monitoring which is charged according to the current price list.
- Own wireless network must be approved in advance by Stockholm International Fairs and will be charged according to the current price list.

MOVING IN AND MOVING OUT

- Earlier moving in can be authorised by Stockholm International Fairs, e-mail: earliermovingin@stofair.se, fax: +46 8-749 42 21. There will be an additional charge per stand according to the current price list.
- Work outside the official moving in and moving out times can be authorised by the Security Manager at Stockholm International Fairs, e-mail: sakerhet@stofair.se, telephone: +46 8-749 41 00, telefax: +46 8-99 66 36. Charged according to the current price list.
- Moving in and moving out is done via the transport entrances for Halls A, B or C. Moving in or moving out via the main entrance, or the east entrance, is not permitted.
- The halls are open for moving in 07.00 – 20.00 hours. On the last evening, all construction must be completed by 16.00 hours. All goods handling that requires truck driving shall be completed by then. After that, empty packaging is driven out of the halls, and aisle carpets are laid. The aisles must then be clear of goods. Work on the stands may continue until 22.00 hours.
- Divergent official moving in and moving out times are notified in separate notices sent to exhibitors.

STAND WALLS

- The normal measurements of stand walls at Stockholm International Fairs are as follows: height 2.5 m, width 1.0 m, thickness 3 cm.
- The stand walls consist of fibreboard panels or similar materials, painted white.
- The stand walls cannot be loaded with heavy objects, but lightweight boards and advertising material can be put up (max 5 kg per wall module).

- The stand walls are not intended for securing or supporting etc your own stand systems. On the upper edge of the walls, an electrical power supply strip is fitted.
- The stand walls are braced along the outer edge by support fixtures, 1,5 m high with a base width of 0.37 m. Support fixtures are mounted on every fourth wall. There may also be other types of all support, such as top and bottom brackets, to hold the walls together. Supports must not be removed without permission from the appropriate hall manager. The supports may be replaced by some other acceptable means, at the exhibitor's expense.
- In cases where a fascia board is constructed in connection with wall construction one post is mounted for every fourth running metre. The post can be removed and replaced with extra ordered wires at the expense of the exhibitor. The ramp cannot be used as a support or securing device of one's own stand system/material, but is only intended for lightweight advertising material.
- Walls should be cleaned of all staples, adhesive mounts, tape and similar. Any cleaning not carried out by the exhibitor will be debited at an hourly rate or the cost of the destroyed wall.
- Walls damaged by filling, wallpapering, screw holes or by being painted in paint not approved by Stockholm International Fairs will be charged to the exhibitor.
- Painting with paint with gloss greater than 5, or wallpapering, may only be done on chipboard-faced walls.

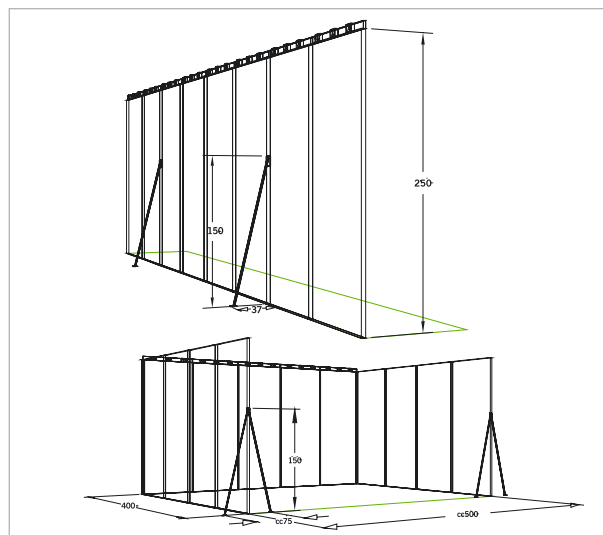

CONSTRUCTION OF UNITS HIGHER THAN 2.5 M AND ADVERTISING PILLARS, SIGNS, ETC.

- The construction height permitted in the trade fair halls is 2.5 m. For light-emitting ceilings, 2.75 m is allowed. For stand constructions, signs, product placements or decorations that exceed the specified heights, an application for exemption must be sent with drawings to Stockholm International Fairs no later than 4 weeks before the trade fair. Apply to Exhibitor Services, telephone: +46 8-749 44 44, telefax: +46 8-99 70 05, e-mail: us@stofair.se
- Stockholm International Fairs reserve the right to refuse permission for late applications.
- Exemption can only be given under the following conditions:
 - Any construction higher than 2.5 m may not be placed closer than 3 m from the stand boundary of a neighbouring stand. The construction of a fully covering stand wall facing an aisle/neighbouring stand must be approved by Stockholm International Fairs. Stockholm International Fairs may make exceptions if it is deemed that the construction is not intrusive, or if permission has been given by the neighbours affected.
 - Constructions must meet all requirements set out in the Swedish construction standards, as far as materials etc. are concerned, and be classified in accordance with the applicable fire safety regulations.
 - The person in charge of the construction (stand constructor) is responsible for safety and construction management.
 - Stockholm International Fairs shall bear no responsibility for implementing designs and for construction work.
 - Exhibitors pay a special fee of SEK 5,000 for increased exhibition area for advertising units which exceed the exhibition's maximum height of 2.5 m.

CONSTRUCTION ON TWO LEVELS FREQUENTED BY BOTH VISITORS AND EXHIBITORS

- Written application with stand designs outlining the possible

construction of a two-level stand must be submitted to Exhibitor Service, telephone : +46 8-749 44 44, telefax: +46 8-99 70 05 at least 4 weeks before the trade fair.

- Stockholm International Fairs reserve the right to refuse permission for late applications.
- The construction of load-bearing joists, walls and ceilings shall adhere to the BBR and BKR regulations, as well as the specific fire and evacuation regulations set by the relevant authorities.
- No work may begin on a two-level stand until Stockholm International Fairs have given permission in writing. Stockholm International Fairs reserve the right to ask for additional information about design, choice of materials, etc.
- The person in charge of the construction (stand constructor) is/are responsible for safety and construction management.
- Stockholm International Fairs bear no responsibility for implementing designs and for construction work.
- All materials used on two-level stands must be classified in accordance with the applicable fire regulations.
- The second level may contain a maximum of 50% of the surface area of the first level.
- The free height on the bottom level must be max 2.5 m and min 2.3 m. the total height of the stand may be a maximum 5 m.
- The distance between two separate two-level constructions must be at least 10 m. Approval may be given even if neighbouring stands have been given permission.
- Exhibitors must also pay stand hire for the 2nd level.
- See also Fire regulations

STAND DIMENSION AND OWN STAND SYSTEMS

In those cases when a hired stand area is equipped with two adjacent units the stated width dimension is the 'central dimension'. This means that the available stand width is reduced by 3 cm. It is important that you notify Exhibitor Service 4 weeks before the fair opens if you have your own stand system or if for some other reason, the exact construction dimensions are needed for your stand.

ELECTRICAL INSTALLATIONS

- Electrical installations in the stand may only be carried out by an authorised electrician. as the electricity network is divided into sections, the current for the respective sections cannot be engaged for safety reasons, until all the installations in the same section have been made.
- Electrical power supply strips are fitted along the tops of the Stockholm International Fairs walls. These must not be blocked by exhibitors' own materials. Only electrical power sockets that have been ordered may be used.
- Spotlights may not protrude more than 30 cm over an aisle.
- All electrical installations and equipment must adhere to the applicable HT-current regulations.
- All connections to the hall's fixed installations must be carried out by an electrical contractor authorised by Stockholm International Fairs.

ELECTRICITY, WATER, HEATING AND SANITATION

When placing units which require water, drainage, compressed air or power outlets, it is important to take into consideration the service channels in the floor. The position of the service channels is normally marked by two dotted lines on the drawing of the proposed position. Make use of the service channels when planning the stand. This will avoid the nuisance of pipes and cabling on the floor.

NIGHT AND CONSTRUCTION POWER

Night and construction Power (power during moving in and moving out) must be ordered latest 4 weeks prior to the fair. Night power and construction power cannot be ordered during moving in.

Stand power supply is switched off each day about one hour after the fair closes. Consequently night-time power supply for refrigerators, computers etc requiring 24-hr electrical power supply has to be ordered.

Night power supply points are clearly marked.

Stockholm International Fairs are not liable for any damage incurred to equipment connected to the standard power supply network.

If you have planned to use fridges or freezers it is necessary to order a power connection with night power.

Regarding computers it is important to order night power if continuous operation of your equipment is needed.

Stockholm International Fairs do not compensate for any damaged of products if connections are made to the closable electricity supply network.

CARPETS

When laying carpets only certain tapes are allowed, these can be bought at the service centre. Note that tape must be removed after the fair. Repairs of damage to floors will be charged to the exhibitor.

PAINTING

No products containing organic solvents may be used. Examples of such solvents are contact glue, spray paint, paints with petroleum spirit or

thinner as solvent, etc. This applies before, during or after the exhibition. Special permission for spray painting must be obtained from the fair, telephone +46 8 749 44 44, fax +46 8 99 70 05.

The above is based on the environmental act, chapter 2, §2-8 and on Swedish Board of Occupational Safety and Health regulations, AFS 2000: 4, §4-5.

- All paint work done on stand walls comes with a charge for restoration.
- The painting of floors is not allowed
- Own restoration is not allowed.

2. Fire safety regulations for exhibitors

MATERIALS/DECOR

- Stand walls and ceilings shall be made of classified fire-retardant materials, i.e., as good or better than wood. Particle board, non-porous fibreboard, plywood, etc., are acceptable.
- Ceilings on covered or enclosed stands greater than 30 m² require sprinkling or fireguards. In choosing materials for ceilings exceeding 30 m², the Security Officer at the trade fair must be contacted, telephone +46 8 749 42 12, fax +46 8 99 66 36.
- Fire-retardant materials must be approved according to one or more of the following classifications: SS 02 48 21, SIS 65 00 82, Euroclass A1, A2 or B-s1.d0. Approval or certificates must be on hand at the display, if it is not clear in any other way that the material in question is safe. Type approval can be replaced by a written statement from Statens Provningsanstalt [Swedish National Testing and Research Institute]. Type approval or certificates must be available in the stand, unless it is made clear in some other way that the material can be approved. Cloth ceilings and other décor must be impregnated against fire. Impregnating agents can be purchased at the Service centre.

TWO-LEVEL STANDS

- The number of steps for a two-level stand is determined by the distance from the steps to the aisle, this distance must not exceed 10 m.
- The required step width is determined by the surface area of the upper level. For a surface area of up to 15 m², the step must be at least 0.8 m wide. For every additional 15 m², a further 0.8 m step width is required. 2 x 0.8 m can be replaced with a 1 x 1.2 m straight step. Spiral staircases must not be less than 0.9 m wide.
- Note! The area between the aisle and the steps must be kept clear at all times.

PACKAGING AND OTHER MATERIAL

Empty packaging or other flammable material must not be stored around the stand or exhibition hall. Material left at the stand is classed as waste and the exhibitor will be invoiced for its disposal.

MOTOR VEHICLES, WORK MACHINES AND TRAILERS

Motor vehicles, work machines and trailers may be driven into the halls only after special permission has been granted. An idling-speed ban applies both in and outside of the halls. The fuel tank must be fitted with a locked lid. On LPG-powered vehicles, the stopcock nearest to the tank (container) must be closed.

FLAMMABLE AND EXPLOSIVE GOODS, HOT WORK AND SMOKE FORMATION

- The handling and storing of flammable liquids or gases must be reported in writing in good time before the trade fair to the Security Manager at Stockholm International Fairs, e-mail: sakerhet@stofair.se, telefax: +46 8-99 66 36. Specify the name of the trade fair and the stand number.
- Explosive or pyrotechnical goods may not under any circumstances be brought in to Stockholm International Fairs without prior written permission from the Security Manager at Stockholm International Fairs, e-mail: sakerhet@stofair.se, telefax: +46 8-99 66 36
- Hot work (e.g. welding, soldering, cutting, circular work, naked flames) is not permitted within the exhibition areas, even during the construction of stands, without special permission, in writing, from the Security Manager of Stockholm International Fairs.
- For activities that emit smoke or gases, such as frying, smoke machines etc., contact Exhibitor Service, telephone +46 8-749 44 44 e-mail: us@stofair.se, telefax: +46 8-99 70 05 for more information.

3. Transport and storage

Goods for the exhibition should be addressed to:
Stockholmsmässan, Godsmottagningen (Goods Inward)
Name of the trade fair/Congress/Conference:
Exhibitor:
Stand number.
Parkeringsvägen 10,
125 80 Älvsjö, (Postal address: 125 80 Stockholm)

GOODS ARRIVING FOR THE TRADE FAIR BEFORE AND DURING MOVING IN

Arriving goods are unloaded and received at Goods Inward. If goods arrive before the official moving in date they are placed in storage, so

that construction of the forthcoming exhibition is not hindered. Once the exhibition has been constructed, and the official moving in is permitted, stored/arriving goods are driven into the exhibition halls. The cost for this is charged to the exhibitor according to the current price list.

BOOKING TIME FOR LOADING /UNLOADING

Applies only to trade fair goods exceeding 1 ton or 4 m³

The enquiry must reach Stockholm International Fairs at least 5 working days before the desired unloading/loading time. Goods without a time booking, or a missed booking, are charged a 50 % surcharge on the current price list.

Enquiries can be made via the website, or by e-mail: logistik@stofair.se, fax: +46 8-749 15 60.

NOTE: Inform your transport company/stand builders about the booked time, to avoid additional costs!

GOODS UNDER CUSTOMER CONTROL TO/FROM STOCKHOLM INTERNATIONAL FAIRS

Incoming exhibition goods under Customs control to Stockholm International Fairs shall on arrival be shown to Goods Inward together with the accompanying transit documentation. If there are any questions, contact Goods Inward on +46 8-749 42 30, e-mail: logistik@stofair.se

RULES FOR THE IMPORT AND EXPORT OF GOODS UNDER CUSTOMS CONTROL

- For incoming exhibition goods under Customs control, Stockholm International Fairs have received permission from Tullverket (the Swedish Customs) to have a temporary warehouse for 20 days from the arrival of the goods at the trade fair.
- Uncleared goods that have been transited to Stockholm International Fairs must be shown on arrival to Goods Inward together with the accompanying transit documentation.
- Before goods can be placed in the stand, the transit document must be sent to Swedish Customs for approval. This is handled by Goods Inward. Once the trade fair has received Swedish Customs approval, the goods are delivered to the stand. Administrative costs are charged to the exhibitor according to the current price list.
- Before the trade fair closes, Goods Inward must have received a transportation voucher or a new transit document for the goods to be transported away from the trade fair. If this is not done, Stockholm International Fairs are entitled to impound the goods until a transportation voucher / transit document is submitted to Goods Inward. Carriage and storage costs according to the current price list.
- If the goods disappear, are sold, thrown away or moved from Stockholm International Fairs without approved Customs documentation such as a transportation voucher or a new transit document for the goods, Stockholm International Fairs will charge the exhibitor any additional costs incurred.

GOODS TRANSPORTATION DURING THE FAIR

During an exhibition, the transport of goods may only be done 1 hour before the trade fair opens. After this only light goods may be taken in.

UNCOLLECTED OR UNLABELLED GOODS

- Stockholm International Fairs are entitled to move and store goods not collected during the moving out time at the exhibitor's expense.
- Unlabelled goods left in the halls once the official moving out time is over, are discarded if the goods cannot be identified.
- Goods that are not collected within 5 days of the moving out time are conveyed at the exhibitor's expense to an agreed address. All handling is charged according to the current price list.

EMPTY PACKAGING

- Empty packaging must be packed and labelled by the exhibitor with the labels provided for the purpose not later than 16.00 hours on the last moving-in day. These labels can be obtained at the Service Centre or at Goods Inward.
- Empty packaging must be packed for truck handling.
- The empty packaging is not available during the exhibition.
- Stockholm International Fairs disclaim responsibility for goods which have been left in empty packaging.
- The handling of empty packaging is charged according to the current price list (minimum charge 2 m³)

KEEPING THE AISLES CLEAR

- Do not place any goods or materials in the aisles outside the stand which might block the way for other transport.
- Stockholm International Fairs are entitled to move all goods and packaging left in the aisles after 16.00 hours on the evening before the exhibition opens, to maintain access. Such goods and packaging will be stored at the exhibitor's expense according to the current price list.

4. Refuse

Stockholm International Fairs environment undertaking requires all exhibitors to sort their day-to-day waste at the waste disposal stations provided. Stockholm International Fairs provides transport from the fair

site and for the destruction of waste products associated with trade fair participation free of charge.

- The environmental stations are located in the halls as well as at the various loading bays.
- Dangerous waste such leftover paint, lamps, fluorescent tubes, batteries, oils and so on, should be turned in to the special environmental stations at the loading bays.
- For larger quantities of waste contact exhibitor service, telephone +46 8 749 44 44, fax +46 8 99 70 05, or the service centre (while the fair is in progress).
- Exhibitors who intend to handle food may order a special bin for food waste from exhibitor service. Bins shall be clearly marked and placed outside the stand. The bins are emptied every day after the fair closes. During daytime hours, bins may be emptied at one of our environmental stations near the loading bays.
- Glass should be sorted into two fractions: "clear" and "coloured".

WASTE PRODUCTS AT THE STAND

You must leave the stand in the condition in which you found it. Each exhibitor is responsible for keeping stands and the area in and around the stand clean during the assembly and dismantling stages. This includes the sorting and disposal of e.g. building waste into the allotted containers. Waste removal can be ordered from the Service Center at a cost of SEK 850/m³ Material left at the stand is classed as waste and the exhibitor will be invoiced for its disposal.

TERMS FOR INSURANCE

Insurance terms and conditions Exhibition Insurance, incl. transport and business travel insurance 1 January 2009, along with text on Liability Insurance.  in cooperation with Stockholm International Fairs.

1. WHO THE INSURANCE POLICY APPLIES TO

The policyholder The insurance policy applies to the policyholder as the owner of an insured exhibition object and to leased exhibition material when the exhibitor is responsible for the risk.

Parties other than the policyholder

The policy also applies to co-exhibitors, companies represented and other owners of an insured exhibition object when they are unable to obtain indemnity through some other insurance policy.

2. WHEN THE INSURANCE POLICY IS APPLICABLE

The insurance policy applies to damage that has occurred while the insurance policy was in force. Insurance including transport

- Begins when, for the purpose of carrying out the transport covered by the insurance policy, the exhibition object leaves the storage premises or depot at the place where the transport is to begin;
- continues during the normal transport and associated loading, reloading and unloading,
- continues during the exhibition and breaks in connection with it;
- continues during normal return transport without unreasonable breaks to the destination, exception point 7, first paragraph;
- ends at the one of the following points that occurs first
 - the exhibition object has been placed in the intended storage site;
 - the exhibition object has been received by the policyholder at some other place;
 - the policyholder has made use of the exhibition object in some other way;
 - 30 days have elapsed since the end of the exhibition.

3. WHERE THE INSURANCE POLICY APPLIES

The insurance policy applies in the EU/EFTA.
For policyholders outside the EU/EFTA the insurance policy only applies in the exhibition area.

4. INSURANCE LIMIT

The insurance applies up to the insurance value stated by Stockholm International Fairs. The insurance limit can be increased for an additional premium.

5. EXCESS

The excess is SEK 1 000 per occurrence of damage/theft.

In the event of a break-in and theft from a party's own vehicles/trailers the excess is 20 per cent of the claim amount; but not less than SEK 5 000.

6. WHAT THE INSURANCE POLICY APPLIES TO

Exhibition objects intended for use at the exhibition.

During an exhibition

The insurance policy applies to damage to or loss of exhibition objects caused by a sudden and unforeseen event.

During transport

The insurance policy applies to damage to or loss of exhibition objects and to costs in a general average.

Extra costs

Direct costs on account of indemnifiable damage are included up to 10 per cent of the insurance limit.

Packaging

Damage to packaging that is to be reused is included.

7. WHAT THE INSURANCE POLICY DOES NOT APPLY TO

Return transport/forwarding of goods sold during the exhibition.

THE INSURANCE POLICY DOES NOT APPLY TO DAMAGE, LOSS OR COSTS CAUSED BY

- non-compliance with the Technical Regulations of Stockholm International Fairs or the provisions of the exhibition facility concerned;
- storage of goods along with empty packaging;
- the exhibition object not being wrapped, packed, loaded in an appropriate manner for the transport;
- soiling, wear, decolouration, scraping, scratching or similar;
- normal handling and use of the object;
- insufficient protection from normal weather conditions;
- the character of the object itself;
- temperature impacts due to the climate;
- time, interest rate and cyclical loss, loss of trading profit, loss of market or any other indirect loss;
- cost of removal and destruction of a damaged object;
- war, warlike conditions, civil war, revolution, disturbances or riots;
- nuclear processes;
- damage due to the breakdown of refrigeration or heating plant.

8. STANDARD OF CARE

- Stands must not be left unsupervised during the opening hours of the exhibition.
- The policyholder or his employees shall handle exhibition objects with care and attention.
- Theft-prone objects shall be kept in locked cases or be padlocked. In

particular, small, easily stolen and valuable objects shall be kept in a locked case.

- After closing time and after the end of the exhibition, theft-prone, valuable objects shall be locked up or padlocked.
- If the standard of care has not been fulfilled, the indemnity is reduced. In certain cases no indemnity at all may be paid.

9. TYPE OF INSURANCE

The insurance is applicable as present value insurance, which means that the insurance value is to correspond to the present value at the time of the loss of property in the stand and of equipment leased from the exhibition.

10. BUSINESS TRAVEL INSURANCE POLICY:

The insurance policy covers:

- Medical and travel costs
- Personal luggage
- Accident insurance, lump sum on death or invalidity

For legal expenses claims the excess is 20 per cent of costs.
General Insurance Terms and Conditions BUSINESS TRAVEL INSURANCE 1 January 2006 points A, B, C, D, E, F, G, H, I, J and General Provisions. General provision of the agreement and definitions.

11. ACTION IN THE EVENT OF DAMAGE

Rescue obligation

The policyholder has the duty to:

- avert damage that can be feared to be imminent,
- limit damage that has already occurred,
- take charge of and protect damaged property as soon as possible.

If the rescue obligation results in increased costs, these will be indemnified within the framework of the maximum insurance limit specified if they have been reasonable in view of the circumstances. The policyholder is obliged to look after his rights and the rights of the insurer in relation to a carrier or other party causing damage.

Notice of claim Damage that can result in an indemnity claim shall be reported as soon as possible. In the event of major damage, if shall be contacted immediately. In addition, the policyholder shall report vandalism, theft, break-ins, assaults or other crimes to the police as soon as possible.

Indemnity claims Indemnity claims shall be presented to the insurer as soon as possible after the occurrence of the damage and no later than 6 months after the policyholder became aware of the damage.

The policyholder is obliged to specify his indemnity claims and provide on request a list of the insured property – both damaged and undamaged – with information about the value of each object before and after the damage.

The policyholder is also obliged to provide on request proof of the indemnity claim by submitting the details available and by providing verifications, certificates and other documents needed to assess the liability of the insurer to pay indemnity and the size of the indemnity. Indemnity is not paid for the costs for the presentation of claims for indemnity.

12. DAMAGE ASSESSMENT RULES

Damage to property is valued at the difference between the present value of the property immediately before and after the damage.

13. DAMAGE INDEMNITY RULES

The policyholder is obliged to prove that the damage/theft has occurred and to also establish the value of the damaged or lost property. If it is judged that it should be possible to repair the damaged property, the policyholder shall await instructions from the insurer before the repair is started. However, indemnity for damaged property can never be higher than the value of the property immediately before the occurrence of the damage. The insurer is always entitled to undertake inspections of the damaged property. If is entitled to decide whether damaged property shall be replaced or an indemnity shall be paid in cash. If the property is not replaced, the amount of the indemnity may be reduced.

14. GENERAL PROVISIONS OF THE AGREEMENT

In other matters the General Swedish Marine Insurance Plan of 2006 applies to this insurance policy.

LIABILITY INSURANCE

The liability insurance covers liability for damage in accordance with the current rules of law of torts for personal injury and damage to property as well as financial loss that is a consequence of a personal injury or property damage that is indemnifiable under the terms and conditions. Damage or injury through a sold product is not covered. The insurance policy covers operations for exhibitors at Stockholm International Fairs in connection with exhibitions on the premises of Stockholm International Fairs.

Exhibitors have no right of recovery in relation to this insurance policy through any liability insurance policies they may have. The insurance limit is SEK 10 000 000 per occurrence of damage or injury and SEK 20 000 000 per insurance year. The deductible is 20 per cent of the base amount. For other matters, reference is made to terms and conditions A140.

CREATING PERFECT MEETINGS

Stockholm International Fairs is the leading organiser in the Baltic Sea Region and organises some 60 industry-leading exhibitions as well as around 100 national and international congresses, conferences and events annually. Every year we welcome 10,000 exhibitors, 1.5 million visitors and more than 8,000 journalists from all over the world.